

Heat Tracing Products

Overview

Industrial Cable Applications

- Self Regulating
- Constant Wattage
- Mineral Insulated

Commercial Cable Applications

- Self Regulating Freeze Protection
- Self Regulating Roof & Gutter De-Icing



Heat tracing is used to counteract the heat lost from process equipment and piping through its insulation. A heat tracing system is a group of process equipment and piping which is heat traced and controlled in a logical and economical manner.

There are many reasons for making up the heat loss of a system. With any heat loss, there is a corresponding drop in temperature.

In many cases, a drop in temperature brings about unacceptable consequences. These consequences could be freezing of water in cooling water lines, steam or condensate return lines, compressed air lines, fire protection lines, storage tanks, valves, etc. A drop in temperature of process fluids could result in solution precipitation, unacceptable viscosity increase or solidification of the product in the lines.

Heat Tracing Products

Applications

Electric Heat Tracing Products

Chromalox heating cable line includes cables suitable for most process maintenance, pipe and vessel freeze protection and roof and gutter de-icing applications.

Industrial Heating Cables are ideal for process maintenance applications. Maintenance temperatures up to 900°F can be achieved in a variety of hazardous and corrosive environments. Industrial Cables include:

SRL — Self-Regulating, Low Temperature

SRM/E — Self-Regulating, Medium Temperature Enhanced

CWM — Constant Wattage, Medium Temperature

MI — Mineral Insulation, High Temperature.

Commercial Application Cables are designed to meet specific needs of winterizing applications such as water line freeze protection and preventing ice damage to building structures. Commercial Cables include:

SRF — Self-Regulating Freeze Protection

SRF-RG — Self-Regulating Roof and Gutter Freeze Protection.

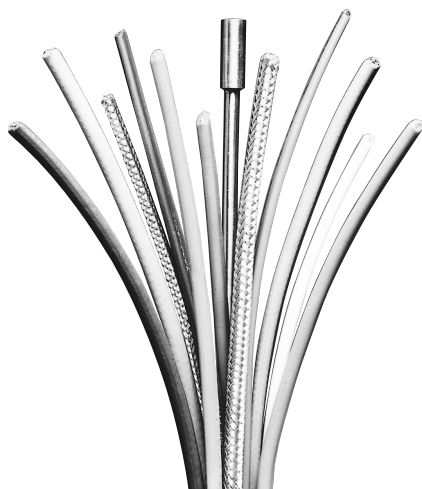

Industrial Process

Maintenance Applications

When industrial process piping and vessels must be maintained above the ambient air temperature, Chromalox has the heating cable to fit the application. Cables range in the maximum maintenance temperature from 150°F for SRL to 900°F for MI cables.

- Petroleum Refineries — Maintain petroleum and by-products at process temperature
- Waste Water Treatment Facilities — Prevent the precipitation of NaOH from solutions
- Food Processing Plants — Maintain viscosity of products in processes such as chocolate, oils and tallow
- Instrument Lines
- Storage Tanks
- Div. 1 and Div. 2 Hazardous Location Applications (Contact your Local Chromalox Sales office for Div. 1 applications)
- Freeze Protection of Steam Cleaned Lines
- Power Generating Plants — Trace steam condensate lines and other chemical additive lines
- Asphalt Lines.

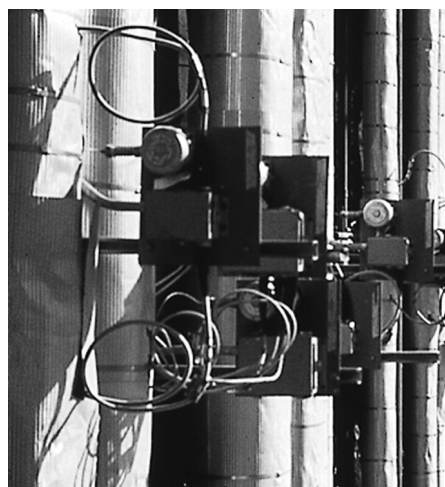

Commercial Applications

In a large number of regions in the world, buildings are susceptible to damage caused by water freezing. Primarily, this damage involves either the bursting of pipes or structural damage due to the weight of ice and snow building up on the roof. Chromalox Commercial Application Cables are intended to prevent this damage.

- Cooling Tower Pipes
- Parking Garage Drain Lines
- Chiller Water Lines
- Exposed Pipe Traps
- Exposed Storm Water Pipes
- Sump Discharge Pipes and Equipment
- Wet Sprinkler Fire Systems, where approved by Local Codes
- Outdoor Sports Facilities and Stadiums
- Roof and Gutter De-icing.

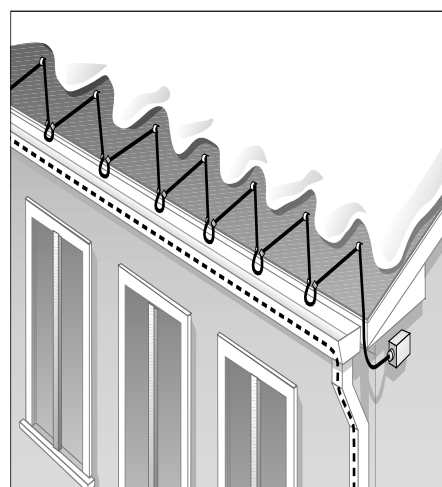

Heat Tracing Products Industrial & Commercial Grade Cables

Heat Tracing Products — Section Outline

Type	Model	Page
Industrial - Application Guidelines		G-4
Self-Regulating Low Temperature Medium Temperature	SRL SRM/E	G-8 G-11
Constant Wattage	CWM	G-14
Mineral Insulated	MI	G-17
Hazardous Location Low Temperature Medium Temperature	HSRL HSRM	G-21 G-24
Commercial - Application Guidelines		G-29
Self-Regulating Freeze Protection Roof & Gutter	SRF SRF-RG	G-27 G-32
Connection Accessories		G-34
DL Series Integrated Connection Accessories	RTPC, RTST, RTES RTPC RTST RTES	G-35 G-36 G-37 G-38

Type	Model	Page
EL Series Standard Connection Accessories	RT-JBC, RT-RST, RT-TST, RT-RES, RT-TES	G-39
General Application Accessories		G-42
HL Hazardous Locations Connection Kits	HL-PC, HL-ES HL-S, HL-T	G-43
B100/E100 Freeze Protection Thermostats		G-45
EL Series Standard Temperature Controls		G-45
RBF Heat Trace or Pipe Sensor		G-47
DL Series Integrated Temperature Controls	RTAS RTBC RTSS	G-48 G-50 G-51
Electronic Controls & Controls Panels		G-52

Industrial Cable Applications

Self-Regulating

Chromalox SRL and SRM/E Self Regulating Heating Cables provide the most versatility in heat trace designs and applications. Constructed of a semiconductive heater matrix extruded between parallel buss wires, a self-regulating cable adjusts its output to independently respond to temperatures all along its length. As temperatures increase, the heater's resistance increases which lowers the output wattage. Conversely, as the temperature decreases, the resistance decreases and the cable produces more heat. The result — an energy efficient heating cable.

Self-regulating cables are flexible, can be cut-to-length in the field and can be single overlapped without fear of burnout in areas where complex piping and equipment require additional heat trace cable.

Chromalox manufactures low (SRL) and medium (SRM/E) temperature self-regulating heating cable for use on 120 and 208 to 277V. Equipped with a ground braid and optional TPR or FEP jacket, Chromalox self-regulating cables are third party tested and approved for use in harsh corrosive and hazardous applications.

Constant Wattage

Chromalox CWM Constant Wattage Heating Cables are ideally suited for applications where a particular watt density is required at all times. The heater element consists of a nichrome wire wrapped around parallel, insulated buss wires. At specific intervals, a short section of insulation is removed from alternating buss wires to create connection

nodes for the nichrome wire. The result is a network of parallel resistors along the entire length of constant wattage cable.

Constant wattage cables are flexible, can be cut-to-length in the field, and are manufactured for use on voltages from 120 to 480V. Although not suited for overlapping, its constant output makes it an ideal choice for higher temperature applications where higher watt densities are required. Equipped with a ground braid and optional FEP jacket, Chromalox constant wattage cables are third party tested and approved for use in harsh, corrosive and hazardous areas. Contact your Local Chromalox Sales office for hazardous area designs.

Mineral Insulated

Chromalox MI Mineral Insulated Heating Cables are the most rugged heating cable in Chromalox's product line. Constructed of a solid series resistor element embedded in highly compacted mineral insulation, MI cables are built to handle high temperature, high wattage applications. The series resistor and mineral insulation are encased in a metallic jacket of Alloy 825 for high temperature or corrosive applications.

Mineral insulated cables are factory assembled and tested, ensuring the highest quality product. Since the units consist of a series resistor, virtually any wattage/voltage/length cable configuration can be produced within the cable's physical operating limits. Chromalox mineral insulated cables are available for use up to 600V and are tested and approved for use in corrosive and hazardous areas. Optional accessories include pulling eyes and reverse glands. Other special features are also available.

Commercial Cable Applications

Self-Regulating Freeze Protection

Chromalox SRF Self Regulating Freeze Protection Heating Cable is a self-regulating cable designed for the freeze protection of water lines. The self-regulating matrix allows for overlapping and easy field installation. SRF also lowers its output and energy consumption as the temperature increases thus lowering energy costs. The 16 AWG buss wires provide for long circuits which reduce the number of accessories required.

A braided and braided with overjacket construction is available. Braided cable should be used on dry pipes and dry locations. The overjacket construction is suitable for wet locations where occasional exposure to moisture is expected.

SRF heating cable is not for use in hazardous locations. Consult the Industrial Cable Products in this section for cables suitable for hazardous locations.

Self-Regulating Roof & Gutter De-Icing

SRF-RG Heating Cable is specifically designed for roof and gutter de-icing applications. SRF-RG features a self-regulating matrix that reduces output as snow melt requirements decrease or when warm weather is present.

The braided and overjacketed construction provides reliable moisture protection. The 16 AWG buss wires allow ample circuit lengths and rugged design. Accessories are available for mounting to roofs and gutters.

Heat Tracing Products

Application & Selection Guidelines

General Product Summary

This section is designed to assist you in determining the appropriate cable for use in your application.

Step 1 — Collect Required Application Data and Determine Heat Loss

Step 2 — Choose the cable that best meets your specific application parameters based on the summary. Consideration of application temperature, exposure temperature, application requirements and environmental ratings should be made.

Step 3 — Select Heating Cable Wattage Rating

Step 4 — Determine Total Cable Required

Step 5 — Determine Circuits and Circuit Protection

Step 6 — Select Appropriate Accessories

Step 1 — Collect Required Application Data & Determine Heat Loss

Application data required can be split into two categories. The first is the heat loss data. This includes:

- Maintenance Temperature
- Minimum Ambient Temperature
- Pipe Size
- Insulation Type (or K factor)
- Insulation Thickness
- Indoor/Outdoor Installation
- Maximum Expected Wind Speed
- Required Safety Factor.

Refer to the Technical section of this catalog, “Determining Heat Energy Requirements —

Pipe & Tank Tracing” for details on performing heat loss calculations. For Commercial Freeze Protection, please see Cable Selection Tables in this section.

The second category of data required is the application and environmental conditions. This includes:

- Maximum Exposure Temperature (Power Off Condition)
- Circuit Length Considerations
- Available Voltage
- Hazardous Area Requirements
- Type of Pipe (Plastic or Metal)
- Chemical Exposure
- Fire Resistance.

Step 2 — Select the Cable

Choose the cable that best fits your specific application parameters and wattage requirements.

Heat Tracing Product Features

Features	Industrial				Commercial	
	SRL	SRM/E	CWM	Alloy 825 MI	SRF	SRF-RG
Max. Maintenance Temp. (°F)	150	302	320	900	100	50
Max. Exposure Temp. (°F) Power Off	185	420	400	1,100	185	185
Max. W/Ft.	10	20	12	50	8	12
Max. Circuit Length (Ft.)	95 - 660	150 - 600	225 - 900	330 - 1,000+	180 - 660	135-540
Buss Wire Size	16	14	12	N/A	16	16
Voltages	120, 208-277	120, 208-277	120, 208-277, 480	Up to 600	120, 208-277	120, 208-277
Hazardous Ratings	Yes	Yes	Yes	Yes	No	No
Usable on Plastic Pipe	Yes	No	No	No	Yes	Yes
Cut-to-Length in Field	Yes	Yes	Yes	No	Yes	Yes
Field Splicable	Yes	Yes	Yes	No	Yes	Yes
Can be Overlapped	Yes	Yes	No	No	Yes	Yes
Output Varies with Temp.	Yes	Yes	No	No	Yes	Yes
Varies Output Along Length	Yes	Yes	No	No	Yes	Yes
Design of System	Simple	Simple	Simple	Involved	Simple	Simple
Installation of System	Easiest	Easiest	Simple	Involved	Easiest	Easiest
Fire Resistance	Fair	Fair	Fair	Excellent	Fair	Fair
Chemical Resistance	See Corrosion Guide, next page					
Size (Max. In.)	0.435 x 0.185	0.5 x 0.2	0.435 x 0.235	0.4	0.435 x 0.185	0.435 x 0.185
Accessories	DL/EL	DL	DL/EL		DL/EL	RG Accessories
Monitor Wire Available	Yes	Contact Factory	Contact Factory	No	No	No
Applications	FL,PL	FL,FH,PL,PH	FL,FH,PL,PH	FL,FH,PL,PH	FL	RG
	FL = Freeze Protection FH = Freeze Protection, High Exposure Temperature PL = Process Maintenance, Low Temperature PH = Process Maintenance, High Temperature RG = Roof and Gutter De-icing					

Heat Tracing Products

Application & Selection Guidelines *(cont'd.)*

Agency Approvals

Cable	UL				CSA				FM			
	Ordinary Area	Class I Div. 2 Groups B, C, D	Class II Div. 2 Groups F, G	Class III Div. 2	Ordinary Area	Class I Div. 2 Groups A, B, C, D	Class II Div. 2 Groups F, G	Class III Div. 2	Ordinary Area	Class I Div. 2 Groups B, C, D	Class II Div. 2 Groups F, G	Class III Div. 2
SRL-C	✓				✓	✓	✓		✓	✓	✓	✓
SRL-CT	✓				✓	✓	✓		✓	✓	✓	✓
SRL-CR	✓				✓	✓	✓		✓	✓	✓	✓
SRM/E-C	✓				✓	✓	✓		✓	✓	✓	✓
SRM/E-CT	✓				✓	✓	✓		✓	✓	✓	✓
CWM-C	✓				✓	✓	✓	✓	✓			
CWM-CT	✓				✓	✓	✓	✓	✓			
MI*	✓	✓	✓	✓	✓	✓	✓	✓	✓	✓	✓	✓
SRF-C	✓				✓				✓			
SRF-CR	✓				✓				✓			
SRF-RG	✓				✓				✓			

For T ratings, refer to individual product pages.
 For more specific information, refer to individual product pages.
 CF=Contact Factory
 *Class I, Division I, Groups B,C & D - UL, CSA, FM - Contact your Local Chromalox Sales office for design assistance.

Corrosion Guide to Select Proper Cable Construction

Exposure To	Industrial				Commercial	
	SRL	SRM/E	CWM	Alloy 825 MI	SRF	SRF-RG
Moisture	C, CR, CT	C, CT	C, CT	Yes	C, CR	Yes
Aqueous Solutions of Inorganic Compounds	CR, CT	CT	CT	No	No	No
Liquids Organic Chemicals	CT	CT	CT	Yes	No	No
Acids or Bases	CT	CT	CT	No	No	No

Note — This is a recommendation guide. Chromalox cannot warrant any Electric Heat Trace against failure by sheath degradation if such failure is the result of operating conditions beyond the control of the heater manufacturer. It is the responsibility of the purchaser to make the ultimate choice of sheath material based on knowledge of the chemical composition of the corrosive solution, character of materials entering the solution, and controls which maintains the process.

Required Jacket Material

Select the appropriate jacket configuration for the desired level of mechanical and corrosive chemical protection. The CR over-jacket option can be used when additional mechanical protection is desired. The CR over-jacket option is required when the cable can be

exposed to aqueous inorganic chemicals. The CT over-jacket option is required when the cable can be exposed to organic chemicals or strong corrosives. Use Corrosion Guide above to determine the correct jacket material option for the cable type selected.



More Information is Available Online on Heat Trace.

Bookmark Your Browser to www.chromalox.com and Select Manuals.

Heat Tracing Products

Application & Selection Guidelines (cont'd.)

Step 3 — Select Heating Cable Wattage Rating

After calculating the heat loss in the pipe and adjusting for any application deviations, you may determine which cable rating to use. If you have selected a self-regulating cable you must adjust the output based on maintenance temperatures, using the Thermal Output Rating Graphs shown on the individual product pages, select the lowest cable rating that will provide the pipe maintenance temperature. **For Example:** A 15 W/Ft. SRM/E cable @ 150°F will output approximately 10 W/Ft. Multiple passes or runs of cable may be required to provide sufficient output per foot calculated in Step 1. This is accomplished with parallel runs of cable or spiraling. Contact your Local Chromalox Sales office.

Cable Output vs. Temperature

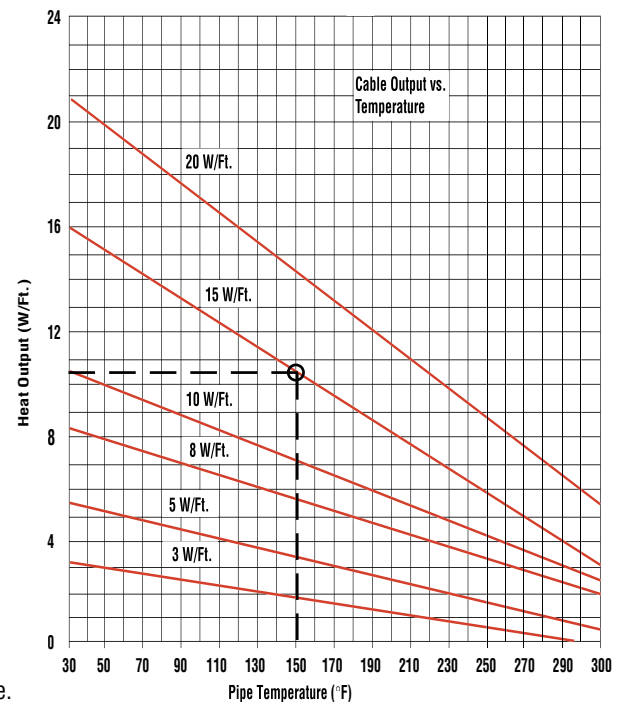

Step 4 — Determine Total Length of Cable Required

The total amount of heating cable is determined by adding the total footage of pipe to be traced and adding for allowances for the components such as flanges, valves, pipe supports; then, multiply by the total number of runs or Wrap Factor determined in Step 3.

(Total Feet of Traced Pipe + Cable Allowance for Components) x # of Runs = Total Cable Length

Step 5 — Determine Circuits & Circuit Protection

Circuit protection depends on the breaker size being used and the start-up temperature. The National Electric Code (NEC 1996) requires the use of ground fault protection breakers for heating cable. Refer to the specific data of the individual heat trace cable to determine maximum circuit lengths. To determine the number of circuits required for each pipe, divide the total cable length found in Step 4 by the maximum circuit length found in the individual cable data charts. Round up to the next higher number.

$$\text{Number of Circuits} = \frac{\text{Cable Length}}{\text{Maximum Circuit Length}}$$

Pipe Component Cable Allowance Estimation

Component	Cable Allowance Factor (Ft.)	x	# Components	Total Additional Cable
Flange Pair	1.5	x		
Pipe Support	2.0	x		
Butterfly Valve	2.5	x		
Ball Valve	2.7	x		
Globe Valve	4.0	x		
Gate Valve	5.0	x		

Example: Pipe: 150 feet
 Valves: 1 globe valve
 Pipe Supports: 2
 Flanges: 2
 Total Cable Length = [150 + (1 x 4) + (2 x 2) + (2 x 1.5)] x 2 runs
 = 161 feet x 2 runs
 = 322 feet

Heat Tracing Products

Application & Selection Guidelines *(cont'd.)*

Design of Multiple Runs when Heat Requirements Exceed Cable Output Ratings

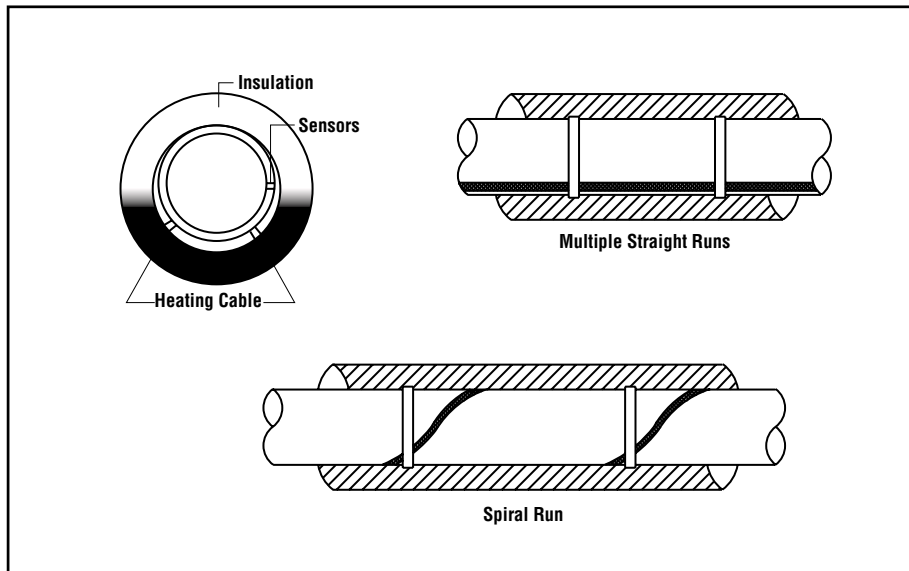

Step 6 — Select Controls & General Application Accessories

Chromalox took a long hard look at the hidden costs that occur in a heat trace project. Indeed this is the labor involved in the installation. Being an innovator, we set out to design a product that went above and beyond what the competition offered while reducing overall installation time and number of parts. The Integrated Connection Accessories (DL) are designed to combine power connections and thermostats in one integrated box. Furthermore, the design offers ease of maintenance and expandability for the future. Of course we offer the standard connection accessories, common to the heat trace industry, which offer lower up front purchase pricing.

Controls

DL — Duraline Integrated Connection Accessories

- Integrated Design — Allows for quick installation with fewer parts
- Lower Man Hours for Installation and Maintenance
- Ease of Maintenance — No replacement of component when doing routine maintenance checks
- Easy to Troubleshoot — Boxes easily open for access to wiring and for taking diagnostic measurements
- Integrated Power Connection and Thermostat — No separate power connection and thermostat box required, resulting in faster installations
- Allows for Future Expansion of System — Because junction, splice and thermostat boxes have multiple cable exits, future cable runs are easily added.

EL — Standard Connection Accessories

- Lower Cost — For use in competitive design and bid installations
- Rugged Cast Junction Box
- Easy to Use Heat Shrink Tubing Kits
- Typical Industry Design — Meets most specifications.

General Application Accessories

For application tape, straps and conduit hubs, refer to the DL & EL General Application Accessories at the end of this section.

For HL kits information, see Product Data Sheet PJ932.



More Information is Available Online on Heat Trace.

Bookmark Your Browser to www.chromalox.com and Select **Manuals**.

Chromalox[®]